

**Features**

- 1-channel isolated barrier
- 24 V DC supply (Power Rail)
- TC, RTD, potentiometer or voltage input
- Current output 0/4 mA ... 20 mA
- Sink or source mode
- Configurable by **PACTware™**
- Line fault (LFD) and sensor burnout detection
- Up to SIL2 acc. to IEC 61508/IEC 61511

**Function**

This isolated barrier is used for intrinsic safety applications. It is designed to connect RTDs, thermocouples, or potentiometers in the hazardous area, and provide a proportional 0/4 mA ... 20 mA signal to the safe area.

The barrier offers 3-port isolation between input, output, and power supply.

A removable terminal block K-CJC-\*\* is available for thermocouples when internal cold junction compensation is desired.

A fault is indicated by a red flashing LED per NAMUR NE44 and user-configured fault outputs.

The unit is easily programmed with the **PACTware™** configuration software.

A collective error messaging feature is available when used with the Power Rail system.

For additional information, refer to the manual and [www.pepperl-fuchs.com](http://www.pepperl-fuchs.com).

**Assembly**

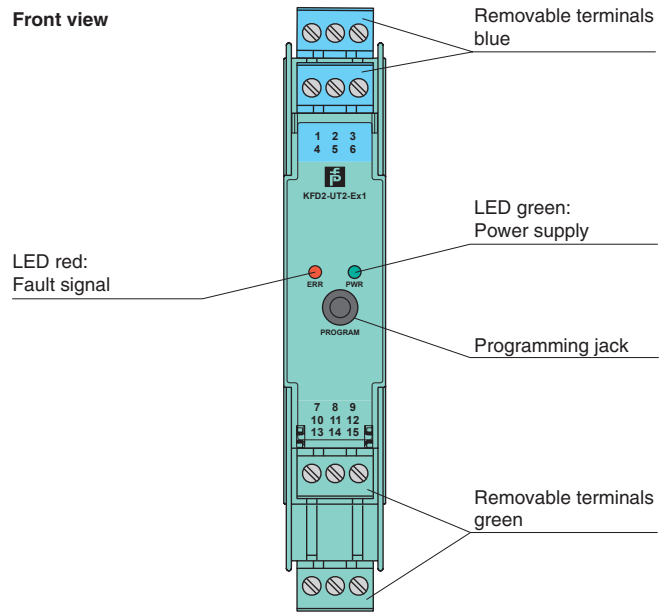

**SIL2**

**Connection**

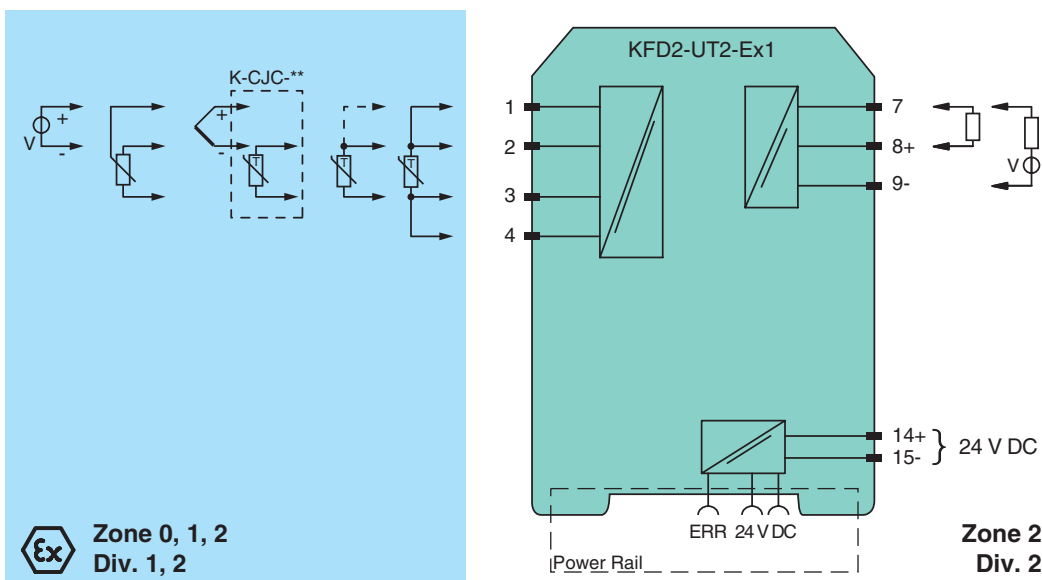

Release date 2012-09-17 12:03 Date of issue 2012-09-17 223812\_eng.xml

<b>General specifications</b>	
Signal type	Analog input
<b>Supply</b>	
Connection	terminals 14+, 15- or power feed module/Power Rail
Rated voltage	20 ... 30 V DC
Ripple	within the supply tolerance
Power loss/power consumption	≤ 0.95 W / 0.95 W
<b>Input</b>	
Connection	terminals 1, 2, 3, 4
RTD	type Pt10, Pt50, Pt100, Pt500, Pt1000 (EN 60751: 1995) type Pt10GOST, Pt50GOST, Pt100GOST, Pt500GOST, Pt1000GOST (6651-94) type Cu10, Cu50, Cu100 (P50353-92) type Ni100 (DIN 43760)
Measuring current	approx. 200 µA with RTD
Types of measuring	2-, 3-, 4-wire connection
Lead resistance	≤ 50 Ω per lead
Measuring circuit monitoring	sensor burnout, sensor short-circuit
Thermocouples	type B, E, J, K, N, R, S, T (IEC 584-1: 1995) type L (DIN 43710: 1985) type TXK, TXKH, TXA (P8.585-2001)
Cold junction compensation	external and internal
Measuring circuit monitoring	sensor burnout
Voltage	selectable within the range -100 ... 100 mV
Potentiometer	0 ... 20 kΩ (2-wire connection), 0.8 ... 20 kΩ (3-wire connection)
Input resistance	≥ 1 MΩ (-100 ... 100 mV)
<b>Output</b>	
Connection	output I: terminal 7: source (-), sink (+), terminal 8: source (+), terminal 9: sink(-)
Output	Analog current output
Current range	0 ... 20 mA or 4 ... 20 mA
Fault signal	downscale 0 or 2 mA, upscale 21.5 mA (acc. NAMUR NE43)
Source	load 0 ... 550 Ω open-circuit voltage ≤ 18 V
Sink	Voltage across terminals 5 ... 30 V. If the current is supplied from a source > 16.5 V, series resistance of $\geq (V - 16.5)/0.0215 \Omega$ is needed, where V is the source voltage. The maximum value of the resistance is $(V - 5)/0.0215 \Omega$ .
<b>Transfer characteristics</b>	
<b>Deviation</b>	
After calibration	<u>Pt100</u> : ± (0.06 % of measurement value in K + 0.1 % of span + 0.1 K (4-wire connection)) <u>thermocouple</u> : ± (0.05 % of measurement value in °C + 0.1 % of span + 1 K (1.2 K for types R and S)) this includes ± 0.8 K error of the cold junction compensation <u>mV</u> : ± (50 µV + 0.1 % of span) <u>potentiometer</u> : ± (0.05 % of full scale + 0.1 % of span, (excludes errors due to lead resistance))
Influence of ambient temperature	deviation of CJC included: <u>Pt100</u> : ± (0.0015 % of measurement value in K + 0.006 % of span)/K $\Delta T_{amb}^{*)}$ <u>thermocouple</u> : ± (0.02 K + 0.005 % of measurement value in °C + 0.006 % of span)/K $\Delta T_{amb}^{*)}$ <u>mV</u> : ± (0.01 % of measurement value + 0.006 % of span)/K $\Delta T_{amb}^{*)}$ <u>potentiometer</u> : ± 0.006 % of span/K $\Delta T_{amb}^{*)}$ $\Delta T_{amb}^{*)}$ = ambient temperature change referenced to 23 °C (296 K)
Influence of supply voltage	< 0.01 % of span
Influence of load	≤ 0.001 % of output value per 100 Ω
Reaction time	sensor burnout and sensor short circuit selected where appropriate mV: 1 s, thermocouples with CJC: 1.1 s, thermocouples with fixed reference temperature: 1.1 s, 3- or 4-wire RTD: 920 ms, 2-wire RTD: 800 ms, Potentiometer: 2.05 s
<b>Electrical isolation</b>	
Output/supply, programming input	functional insulation acc. to IEC 62103, rated insulation voltage 50 V <sub>eff</sub> There is no electrical isolation between the programming input and the supply. The programming cable provides galvanic isolation so that ground loops are avoided.
<b>Directive conformity</b>	
Electromagnetic compatibility	
Directive 2004/108/EC	EN 61326-1:2006
<b>Conformity</b>	
Insulation coordination	UL 61010-1
Electromagnetic compatibility	NE 21:2006
Protection degree	IEC 60529:2001
<b>Ambient conditions</b>	
Ambient temperature	-20 ... 60 °C (-4 ... 140 °F)
<b>Mechanical specifications</b>	
Protection degree	IP20

Release date 2012-09-17 12:03 Date of issue 2012-09-17 223812\_eng.xml

Mass		approx. 130 g
Dimensions		20 x 119 x 115 mm (0.8 x 4.7 x 4.5 in) , housing type B2
Mounting		on 35 mm DIN mounting rail acc. to EN 60715:2001
<b>Data for application in connection with Ex-areas</b>		
EC-Type Examination Certificate		CESI 04 ATEX 143 , for additional certificates see <a href="http://www.pepperl-fuchs.com">www.pepperl-fuchs.com</a>
Group, category, type of protection		⊕ II (1)GD, I (M1), [Ex ia] IIC, [Ex iaD], [Ex ia] I (-20 °C ≤ T <sub>amb</sub> ≤ 60 °C) [circuit(s) in zone 0/1/2]
Input		Ex ia IIC
Inputs		terminals 1, 2, 3, 4
Voltage	U <sub>o</sub>	9 V
Current	I <sub>o</sub>	22 mA
Power	P <sub>o</sub>	50 mW
Analog outputs, power supply, collective error		
Maximum safe voltage	U <sub>m</sub>	250 V (Attention! This is not the rated voltage.)
Interface		
Maximum safe voltage	U <sub>m</sub>	250 V (Attention! The rated voltage is lower.), RS 232
Statement of conformity		
Group, category, type of protection, temperature class		⊕ II 3G Ex nA II T4 [device in zone 2]
Electrical isolation		
Input/Other circuits		safe electrical isolation acc. to IEC/EN 60079-11, voltage peak value 375 V
Directive conformity		
Directive 94/9/EC		EN 60079-0:2006, EN 60079-11:2007, EN 60079-15:2005, EN 60079-26:2007, EN 61241-0:2006, EN 61241-11:2006
<b>International approvals</b>		
UL approval		
Control drawing		116-0316
CSA approval		
Control drawing		366-024CS-12 (cCSAus)
IECEX approval		
Approved for		[Zone 0] [Ex ia] IIC, [Ex iaD], [Ex ia] I
<b>General information</b>		
Supplementary information		EC-Type Examination Certificate, Statement of Conformity, Declaration of Conformity, Attestation of Conformity and instructions have to be observed where applicable. For information see <a href="http://www.pepperl-fuchs.com">www.pepperl-fuchs.com</a> .

## Accessories

### Power feed module KFD2-EB2

The power feed module is used to supply the devices with 24 V DC via the Power Rail. The fuse-protected power feed module can supply up to 100 individual devices depending on the power consumption of the devices. A galvanically isolated mechanical contact uses the Power Rail to transmit collective error messages.

### Power Rail UPR-03

The Power Rail UPR-03 is a complete unit consisting of the electrical inset and an aluminium profile rail 35 mm x 15 mm. To make electrical contact, the devices are simply engaged.

### Profile Rail K-DUCT with Power Rail

The profile rail K-DUCT is an aluminum profile rail with Power Rail insert and two integral cable ducts for system and field cables. Due to this assembly no additional cable guides are necessary.



Attention

*Power Rail and Profile Rail must not be fed via the device terminals of the individual devices!*

### K-CJC-\*\*

This removable terminal block with integrated temperature measurement sensor is needed for internal cold junction compensation for thermocouples. One K-CJC-\*\* is needed for each channel.

### PACT<sup>ware</sup>™

Device-specific drivers (DTM)

### Adapter K-ADP1

Programming adapter for parameterisation via the serial RS 232 interface of a PC/Notebook

For programming, please use the new version of adapter K-ADP1 (part no. 181953, connector length 14mm). When using the previous version K-ADP1 (connector length 18 mm) the plug is exposed by approx. 3 mm. The function is not affected.

### Adapter K-ADP-USB

Programming adapter for parameterisation via the serial USB interface of a PC/Notebook