

Features

- 2-channel signal conditioner
- 24 V DC supply (Power Rail)
- TC, RTD, potentiometer or voltage input
- Current output 0/4 mA ... 20 mA
- Sink or source mode
- Configurable by **PACTware™**
- Line fault (LFD) and sensor burnout detection
- Up to SIL2 acc. to IEC 61508/IEC 61511

Function

This signal conditioner is designed to connect RTDs, thermocouples, or potentiometers, and provide a proportional 0/4 mA ... 20 mA signal.

The barrier offers 3-port isolation between input, output, and power supply.

A removable terminal block K-CJC-** is available for thermocouples when internal cold junction compensation is desired.

A fault is indicated by a red flashing LED per NAMUR NE44 and user-configured fault outputs.

The unit is easily programmed with the **PACTware™** configuration software.

A unique collective error messaging feature is available when used with the Power Rail system.

For additional information, refer to the manual and www.pepperl-fuchs.com.

Assembly

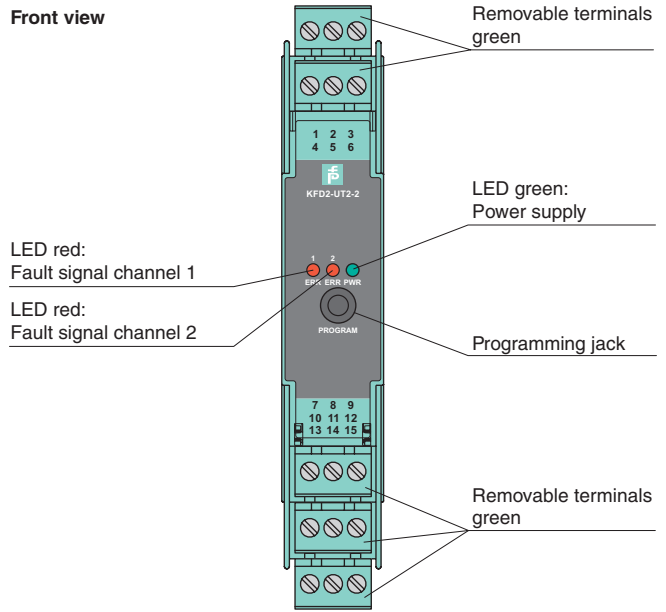

SIL2

Connection

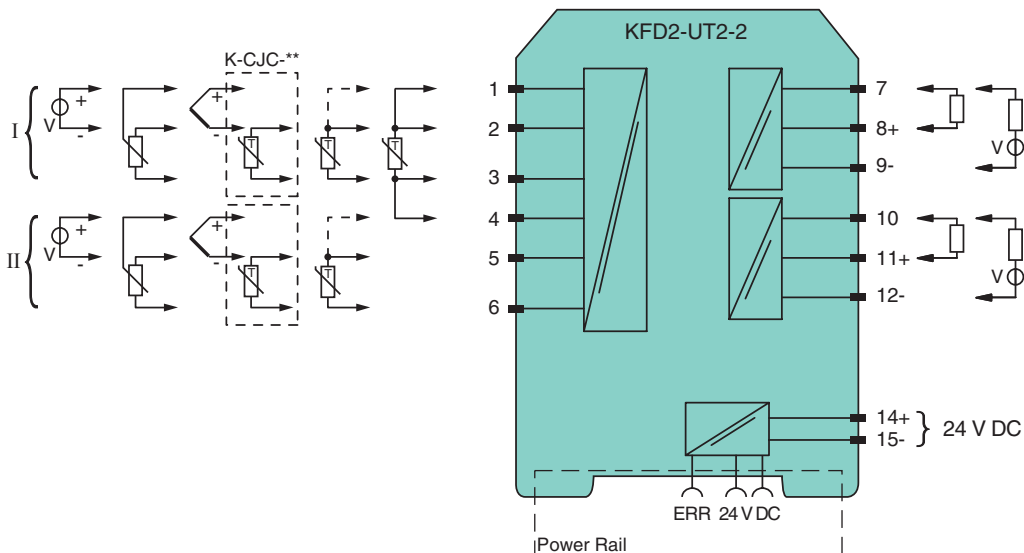

Release date 2012-09-17 12:04 Date of issue 2012-09-17 191888_eng.xml

General specifications	
Signal type	Analog input
Supply	
Connection	terminals 14+, 15- or power feed module/Power Rail
Rated voltage	20 ... 30 V DC
Ripple	within the supply tolerance
Power loss/power consumption	≤ 1.5 W / 1.5 W
Input	
Connection	terminals 1, 2, 3; 4, 5, 6
RTD	type Cu10, Cu50, Cu100, Pt10, Pt50, Pt100, Pt500, Pt1000, Ni100 (EN 60751: 1995) type Pt10GOST, Pt50GOST, Pt100GOST, Pt500GOST, Pt1000GOST (P50353-92)
Measuring current	approx. 200 µA with RTD
Types of measuring	2-, 3-wire connection
Lead resistance	≤ 50 Ω per lead
Measuring circuit monitoring	sensor burnout, sensor short-circuit
Thermocouples	type B, E, J, K, N, R, S, T (IEC 584-1: 1995) type L (DIN 43710: 1985) type TXK, TXKH, TXA (P8.585-2001)
Cold junction compensation	external and internal
Measuring circuit monitoring	sensor burnout
Voltage	selectable within the range -100 ... 100 mV
Potentiometer	0 ... 20 kΩ (2-wire connection), 0.8 ... 20 kΩ (3-wire connection)
Input resistance	≥ 1 MΩ (-100 ... 100 mV)
Output	
Connection	output I: terminal 7: source (-), sink (+), terminal 8: source (+), terminal 9: sink(-) output II: terminal 10: source (-), sink (+), terminal 11: source (+), terminal 12: sink(-)
Output I, II	Analog current output
Current range	0 ... 20 mA or 4 ... 20 mA
Fault signal	downscale 0 or 2 mA, upscale 21.5 mA (acc. NAMUR NE43)
Source	load 0 ... 550 Ω open-circuit voltage ≤ 18 V
Sink	Voltage across terminals 5 ... 30 V. If the current is supplied from a source > 16.5 V, series resistance of $\geq (V - 16.5)/0.0215 \Omega$ is needed, where V is the source voltage. The maximum value of the resistance is $(V - 5)/0.0215 \Omega$.
Transfer characteristics	
Deviation	
After calibration	<u>Pt100</u> : ± (0.06 % of measurement value in K + 0.1 % of span + 0.1 K (4-wire connection)) <u>thermocouple</u> : ± (0.05 % of measurement value in °C + 0.1 % of span + 1 K (1.2 K for types R and S)) this includes ± 0.8 K error of the cold junction compensation <u>mV</u> : ± (50 µV + 0.1 % of span) <u>potentiometer</u> : ± (0.05 % of full scale + 0.1 % of span, (excludes errors due to lead resistance))
Influence of ambient temperature	deviation of CJC included: <u>Pt100</u> : ± (0.0015 % of measurement value in K + 0.006 % of span)/K $\Delta T_{amb}^*)$ <u>thermocouple</u> : ± (0.02 K + 0.005 % of measurement value in °C + 0.006 % of span)/K $\Delta T_{amb}^*)$ <u>mV</u> : ± (0.01 % of measurement value + 0.006 % of span)/K $\Delta T_{amb}^*)$ <u>potentiometer</u> : ± 0.006 % of span/K $\Delta T_{amb}^*)$ $\Delta T_{amb}^*) =$ ambient temperature change referenced to 23 °C (296 K)
Influence of supply voltage	< 0.01 % of span
Influence of load	≤ 0.001 % of output value per 100 Ω
Reaction time	sensor burnout and sensor short circuit selected where appropriate mV: 1.2 s, thermocouples with CJC: 1.4 s, thermocouples with fixed ref. temp: 1.4 s, 3- or 4-wire RTD: 1.1 s, 2-wire RTD: 920 ms, Potentiometer: 3-wire connection 2.8 s, 2-wire connection 2.25 s
Electrical isolation	
Input/Other circuits	safe galvanic isolation acc. to EN 50020, voltage peak value 375 V
Output/supply, programming input	functional insulation acc. to IEC 62103, rated insulation voltage 50 V _{eff} There is no electrical isolation between the programming input and the supply. The programming cable provides galvanic isolation so that ground loops are avoided.
Directive conformity	
Electromagnetic compatibility	
Directive 2004/108/EC	EN 61326-1:2006
Conformity	
Electromagnetic compatibility	NE 21:2006
Protection degree	IEC 60529:2001
Ambient conditions	
Ambient temperature	-20 ... 60 °C (-4 ... 140 °F)
Mechanical specifications	
Protection degree	IP20
Mass	approx. 130 g

Release date 2012-09-17 12:04 Date of issue 2012-09-17 191888_eng.xml

Dimensions	20 x 119 x 115 mm (0.8 x 4.7 x 4.5 in) , housing type B2
Mounting	on 35 mm DIN mounting rail acc. to EN 60715:2001
General information	
Supplementary information	Statement of Conformity, Declaration of Conformity, Attestation of Conformity and instructions have to be observed where applicable. For information see www.pepperl-fuchs.com .

Accessories

Power feed module KFD2-EB2

The power feed module is used to supply the devices with 24 V DC via the Power Rail. The fuse-protected power feed module can supply up to 100 individual devices depending on the power consumption of the devices. A galvanically isolated mechanical contact uses the Power Rail to transmit collective error messages.

Power Rail UPR-03

The Power Rail UPR-03 is a complete unit consisting of the electrical inset and an aluminium profile rail 35 mm x 15 mm. To make electrical contact, the devices are simply engaged.

Profile Rail K-DUCT with Power Rail

The profile rail K-DUCT is an aluminum profile rail with Power Rail insert and two integral cable ducts for system and field cables. Due to this assembly no additional cable guides are necessary.



Attention

Power Rail and Profile Rail must not be fed via the device terminals of the individual devices!

K-CJC-**

This removable terminal block with integrated temperature measurement sensor is needed for internal cold junction compensation for thermocouples. One K-CJC-** is needed for each channel.

PACTware™

Device-specific drivers (DTM)

Adapter K-ADP1

Programming adapter for parameterisation via the serial RS 232 interface of a PC/Notebook

For programming, please use the new version of adapter K-ADP1 (part no. 181953, connector length 14mm). When using the previous version K-ADP1 (connector length 18 mm) the plug is exposed by approx. 3 mm. The function is not affected.

Adapter K-ADP-USB

Programming adapter for parameterisation via the serial USB interface of a PC/Notebook