

Features

- 1-channel isolated barrier
- AC/DC wide range supply
- Input for NAMUR sensors or dry contacts
- Input frequency 1 mHz ... 5 kHz
- Current output 0/4 mA ... 20 mA
- Relay and transistor output
- Start-up override
- Line fault detection (LFD)
- Up to SIL2 acc. to IEC 61508/IEC 61511

Function

This isolated barrier is used for intrinsic safety applications.

The device is a universal frequency converter that changes a digital input signal into a proportional free adjustable 0/4 mA ... 20 mA analog output signal and functions as a switch amplifier and a trip alarm.

The functions of the switch outputs (2 relay outputs and 1 potential free transistor output) are easily adjustable [trip value display (min/max alarm), serially switched output, pulse divider output, error signal output].

The device is easily configured by the use of keypad or with the PACTware configuration software.

A fault is signaled by LEDs acc. to NAMUR NE44.

For additional information, refer to the manual and www.pepperl-fuchs.com.

Assembly

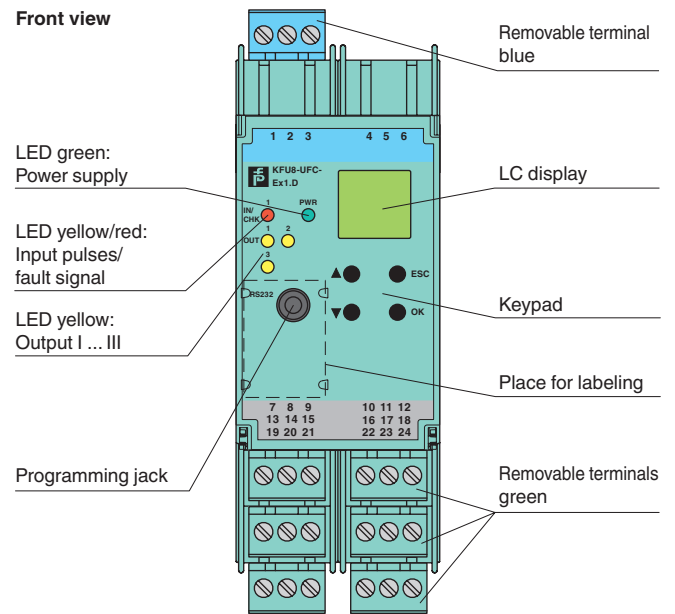

Connection

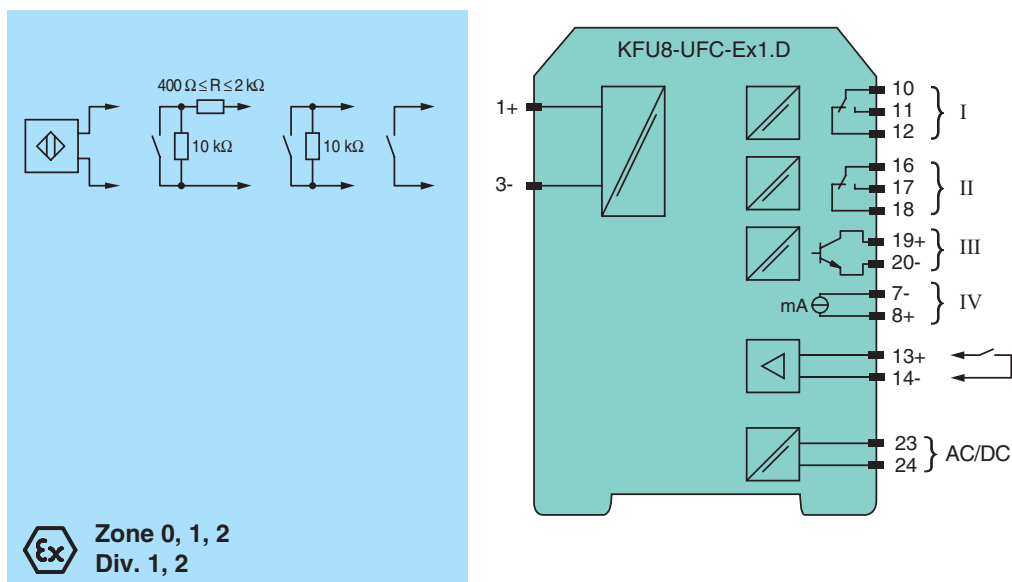

Release date 2012-05-21 17:16 Date of issue 2012-05-21 231197_eng.xml

General specifications	
Signal type	Digital Input
Supply	
Connection	terminals 23, 24
Rated voltage	20 ... 90 V DC / 48 ... 253 V AC 50 ... 60 Hz
Power loss/power consumption	≤ 2 W ; 2.5 VA / 2.2 W ; 3 VA
Input	
Connection	Input I: intrinsically safe: terminals 1+, 3- Input II: non-intrinsically safe: terminals 13+, 14-
Input I	sensor acc. to EN 60947-5-6 (NAMUR) or mechanical contact
Pulse duration	> 50 μs
Input frequency	0.001 ... 5000 Hz
Lead monitoring	breakage I ≤ 0.15 mA; short-circuit I > 6.5 mA
Input II	startup override: 1 ... 1000 s, adjustable in steps of 1 s
Active/Passive	I > 4 mA (for min. 100 ms) / I < 1.5 mA
Open circuit voltage/short-circuit current	18 V / 5 mA
Output	
Connection	output I: terminals 10, 11, 12 output II: terminals 16, 17, 18 output III: terminals 19+, 20- output IV: terminals 8+, 7-
Output I, II	signal, relay
Contact loading	250 V AC / 2 A / $\cos \phi \geq 0.7$; 40 V DC / 2 A
Mechanical life	5 x 10 ⁷ switching cycles
Energized/De-energized delay	approx. 20 ms / approx. 20 ms
Output III	electronic output, passive
Contact loading	40 V DC
Signal level	1-signal: (L+) - 2.5 V (50 mA, short-circuit/overload proof) 0-signal: switched off (off-state current ≤ 10 μA)
Output IV	analog
Current range	0 ... 20 mA or 4 ... 20 mA
Open loop voltage	≤ 24 V DC
Load	≤ 650 Ω
Fault signal	downscale I ≤ 3.6 mA , upscale ≥ 21.5 mA (acc. NAMUR NE43)
Transfer characteristics	
Input I	
Measurement range	0.001 ... 5000 Hz
Resolution	0.1 % of the measurement value , ≥ 0.001 Hz
Accuracy	0.1 % of the measurement value , > 0.001 Hz
Measuring time	< 100 ms
Influence of ambient temperature	0.003 %/K (30 ppm)
Output I, II	
Response delay	≤ 200 ms
Output IV	
Resolution	< 10 μA
Accuracy	< 20 μA
Influence of ambient temperature	0.005 %/K (50 ppm)
Electrical isolation	
Input I/other circuits	reinforced insulation according to IEC/EN 61010-1, rated insulation voltage 300 V _{eff}
Output I, II/other circuits	reinforced insulation according to IEC/EN 61010-1, rated insulation voltage 300 V _{eff}
Mutual output I, II, III	reinforced insulation according to IEC/EN 61010-1, rated insulation voltage 300 V _{eff}
Output III/power supply	reinforced insulation according to IEC/EN 61010-1, rated insulation voltage 300 V _{eff}
Output III/start-up override	basic insulation according to IEC/EN 61010-1, rated insulation voltage 50 V _{eff}
Output III/IV	basic insulation according to IEC/EN 61010-1, rated insulation voltage 50 V _{eff}
Output IV/power supply	reinforced insulation according to IEC/EN 61010-1, rated insulation voltage 300 V _{eff}
Start-up override/power supply	reinforced insulation according to IEC/EN 61010-1, rated insulation voltage 300 V _{eff}
Interface/power supply	reinforced insulation according to IEC/EN 61010-1, rated insulation voltage 300 V _{eff}
Interface/output III	basic insulation according to IEC/EN 61010-1, rated insulation voltage 50 V _{eff}
Directive conformity	
Electromagnetic compatibility	
Directive 2004/108/EC	EN 61326-1:2006
Low voltage	
Directive 2006/95/EC	EN 61010-1:2010
Conformity	

Release date 2012-05-21 17:16 Date of issue 2012-05-21 231197_eng.xml

Electromagnetic compatibility	NE 21:2006
Protection degree	IEC 60529:2001
Input	EN 60947-5-6:2000
Ambient conditions	
Ambient temperature	-20 ... 60 °C (-4 ... 140 °F)
Mechanical specifications	
Protection degree	IP20
Mass	300 g
Dimensions	40 x 119 x 115 mm (1.6 x 4.7 x 4.5 in) , housing type C3
Mounting	on 35 mm DIN mounting rail acc. to EN 60715:2001
Data for application in connection with Ex-areas	
EC-Type Examination Certificate	TÜV 99 ATEX 1471 , for additional certificates see www.pepperl-fuchs.com
Group, category, type of protection	Ⓔ II (1)GD, I (M1) [Ex ia] IIC, [Ex iaD], [Ex ia] I (-20 °C ≤ T _{amb} ≤ 60 °C)
Supply	
Maximum safe voltage U _m	253 V AC / 125 V DC (Attention! U _m is no rated voltage.)
Input I	
Voltage U _o	10.1 V
Current I _o	13.5 mA
Power P _o	34 mW (linear characteristic)
Input II	
Maximum safe voltage U _m	40 V (Attention! The rated voltage can be lower.)
Output I, II	
Maximum safe voltage U _m	253 V (Attention! The rated voltage can be lower.)
Contact loading	253 V AC/2 A/cos φ > 0.7; 40 V DC/2 A resistive load (TÜV 99 ATEX 1471)
Output III	
Maximum safe voltage U _m U _m	40 V (Attention! U _m is no rated voltage.)
Output IV	
Maximum safe voltage U _m	40 V DC (Attention! U _m is no rated voltage.)
Interface	
Maximum safe voltage U _m	40 V (Attention! U _m is no rated voltage.)
Electrical isolation	
Input I/other circuits	safe electrical isolation acc. to IEC/EN 60079-11, voltage peak value 375 V
Directive conformity	
Directive 94/9/EC	EN 60079-0:2009, EN 60079-11:2007, EN 60079-26:2007 , EN 61241-11:2006
International approvals	
FM approval	
Control drawing	16-538FM-12
General information	
Supplementary information	EC-Type Examination Certificate, Statement of Conformity, Declaration of Conformity, Attestation of Conformity and instructions have to be observed where applicable. For information see www.pepperl-fuchs.com .

Accessories

PACTware™
 Device-specific drivers (DTM)

Adapter K-ADP1
 Programming adapter for parameterisation via the serial RS 232 interface of a PC/Notebook
 For programming, please use the new version of adapter K-ADP1 (part no. 181953, connector length 14mm). When using the previous version K-ADP1 (connector length 18 mm) the plug is exposed by approx. 3 mm. The function is not affected.

Adapter K-ADP-USB
 Programming adapter for parameterisation via the serial USB interface of a PC/Notebook

Release date 2012-05-21 17:16 Date of issue 2012-05-21 231197_eng.xml